



Electrische Lier DM/DT / Electric Winch DM/DT

Eigenschappen

- » Geschikt voor hijs- en trekwerkzaamheden.
- » Geschikt voor een breed scala aan industriële toepassingen.
- » Hoge inschakelduur.
- » Permanent gesmeerde transmissie, zorgt voor een soepele en stille werking.
- » Geleverd klaar voor gebruik met bedieningsschakelaar, voedingskabel en staalkabel met haak.
- » Voldoet aan de Machinerichtlijn 2006/42/EG. Geleverd met testcertificaat, CE-conformiteitsverklaring en gebruiksaanwijzing.

Features

- » Suitable for lifting and pulling applications.
- » Suitable for a wide range of industrial applications.
- » High duty cycle.
- » Permanently lubricated transmission, ensures smooth and quiet operation.
- » Supplied ready to use with control switch, power cable and steel cable with load hook.
- » Complies with the Machinery Directive 2006/42/EC. Supplied with test certificate, CE declaration of conformity and operating instructions.



DI.0.DM.200

Specificaties / Specifications							
Artikel nummer	Capaciteit	Voltage	Hijshoogte	Max. hijssnelheid	Staaldraad	Energie verbruik	Gewicht
Article code	Capacity	Operating voltage	Hoisting height	Max. lifting speed	Steel cable	Power output	Weight
	ton		m	m/min	m x Ømm	kW	kg
DI.0.DM.100	0.1	230V	14	15	16 x 4	0.3	15
DI.0.DM.150	0.15		16	21	18 x 4	0.65	22
DI.0.DM.200			23	25	25 x 5	0.75	37
DI.0.DM.200.48	0.2		48	38	50 x 5	1.45	43
DI.0.DM.200.98			98	38	100 x 5	1.45	50
DI.0.DM.300	0.3		23	23	25 x 6	1.45	47
DI.0.DM.300.38			38	23	40 x 6	1.45	50
DI.0.DM.500	0.5		23	16	25 x 7	2.2	64
DI.0.DM.500.38			38	16	40 x 7	2.2	68

Specificaties / Specifications	
Toepassing / Application	Hijsslier / Hoisting winch
Voltage / Operating voltage	230V / 50Hz / 1Ph / 400V / 50Hz / 3Ph (440V/60Hz op aanvraag/on request)
Hijssnelheid / Lifting speed	Enkele snelheid / Single speed
Kabel / Cable	Staalkabel 1960 N/mm <sup>2</sup> / Steel cable 1960 N/mm <sup>2</sup>
Stuurkabel / Control cable	Standaard ≈1 meter / Standard ≈1 meter
Stroomkabel / Power cable	≈1 meter met stekker / ≈1 meter with plug
Behuizing bescherming / Housing protection	IP 55 (100-200kg IP 44)
Besturing bescherming / Control protection	IP 65
Classificatie / Classification	M5/2m (ISO/FEM)
Inschakelduur / Starts per uur / Duty cycle / Starts per hour	50% / 240
Isolatieklasse / Insulation class	F
Bedrijfstemperatuur / Operating temperature	-10°C - +40°C
Lading type / Load type	Alleen voor goederen, niet geschikt om personen te hijsen / Goods, may not be used to lift people

Beveiliging / Protection	
Schakelaar / Control switch	230/400V schakelaar met noodstop / 230/400V pendant control switch with emergency stop button
Overlastbeveiliging / Overload protection	Zonder overlastbeveiliging / No overload protection
Rem / Brake	Mechanische rem, bereikt onmiddellijk remeffect en houdt de lading ook bij stroomuitval stevig vast / Mechanical brake, achieves immediate braking and holds the load in the event of power failure
Eindschakelaar / Limit switch	Mechanische hoogste eindschakelaar / Mechanical upper limit switch



Electrische Lier DM/DT / Electric Winch DM/DT

Optioneel / Optional



DI.0.DM.100



DI.0.DM.300

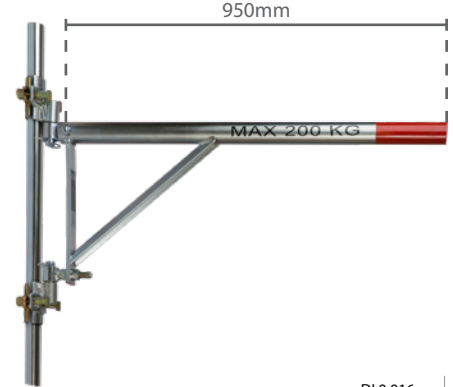

DI.0.016

Zwaaiarm met koppelingen / Jib with hinges  
Voor eenvoudige ophanging aan steigers. (max. 200kg)  
For easy suspension from scaffolds. (max. 200kg)



DI.0.DM.500



B

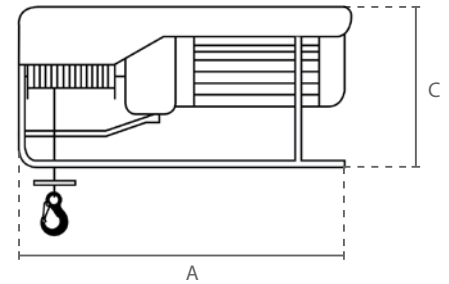

A

C

Specificaties / Specifications

Artikel nummer Article code	Capaciteit Capacity ton	Voltage Operating voltage	Hijshoogte Hoisting height m	Max. hijssnelheid Max. lifting speed m/min	Staaldraad Steel cable m x Ømm	Energie verbruik Power output kW	Gewicht Weight kg
DI.0.DT.300	0.3	400V	23	23	25 x 6	1.85	47
DI.0.DT.300.38			38	23	40 x 6	1.85	50
DI.0.DT.500			23	22	25 x 7	2.2	64
DI.0.DT.500.38	0.5		38	22	40 x 7	2.2	68
DI.0.DT.950			23	12	25x2 x 7	2.2	75
DI.0.DT.950.38			38	12	40x2 x 7	2.2	84

Afmetingen / Dimensions

Artikel nummer Article code	A	B	C	J	K
DI.0.DM.100	375	170	240	26	22
DI.0.DM.150	415	210	310	26	22
DI.0.DM.200 / 48	510	300	385	26	22
DI.0.DM.200.98	720	300	385	26	22
DI.0.DM.300	580	305	410	26	22
DI.0.DM.500	600	300	470	26	22
DI.0.DT.300	580	305	410	26	22
DI.0.DT.500	600	300	470	26	22
DI.0.DT.950	600	300	470	36	25

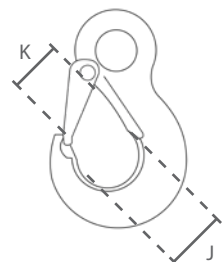



## Elektrische Seilwinde DM/DT / Treuil électrique DM/DT

## Eigenschaften

- » Ausgelegt für Hub- und Zugarbeiten.
- » Ausgelegt für eine Vielzahl von industriellen Anwendungen.
- » Hohe Einschaltdauer und hoher Arbeitszyklus.
- » Permanent geschmiertes Getriebe, sorgt für reibungslosen und geräuscharmen Betrieb.
- » Betriebsfertig geliefert mit Steuerschalter, Stromkabel und Stahlkabel mit Lasthaken.
- » Erfüllt die Maschinenrichtlinie 2006/42/EG. Geliefert mit Prüfzeugnis, CE Konformitätserklärung und Betriebsanleitung.

## Caractéristiques

- » Conçu pour les travaux de levage et de traction.
- » Convient à une large gamme d'applications industrielles.
- » Facteur de marche élevé ainsi qu'un cycle de marche élevé.
- » La lubrification permanente de la transmission assure un fonctionnement sans faille et silencieux.
- » Livré prêt à l'emploi avec boîte de commande, câble d'alimentation et câble en acier avec crochet de charge.
- » Conforme à la Directive Machines 2006/42/CE. Livré avec certificat de contrôle, déclaration CE de conformité et mode d'emploi.



DI.0.DM.200

## Technische Daten / Spécifications

Artikelnummer	Tragfähigkeit	Betriebsspannung	Hubhöhe	Max. Hubgeschwindigkeit	Stahlkabel	Leistung	Eigengewicht
Code de l'article	Capacité	Tension de fonctionnement	Hauteur de levage	Max. vitesse de levée	Câble en acier	Puissance	Poids
	ton		m	m/min	m x Ømm	kW	kg
DI.0.DM.100	0.1	230V	14	15	16 x 4	0.3	15
DI.0.DM.150	0.15		16	21	18 x 4	0.65	22
DI.0.DM.200			23	25	25 x 5	0.75	37
DI.0.DM.200.48	0.2		48	38	50 x 5	1.45	43
DI.0.DM.200.98			98	38	100 x 5	1.45	50
DI.0.DM.300			23	23	25 x 6	1.45	47
DI.0.DM.300.38	0.3		38	23	40 x 6	1.45	50
DI.0.DM.500			23	16	25 x 7	2.2	64
DI.0.DM.500.38	0.5		38	16	40 x 7	2.2	68

## Technische Daten / Spécifications

Anwendung / Application	Hubwinde / Treuil de levage
Betriebsspannung / Tension de fonctionnement	230V / 50Hz / 1Ph / 400V / 50Hz / 3Ph (440V/60Hz auf Anfrage/sur demande)
Hubgeschwindigkeit / Vitesse de levée	Haupthub / Simple vitesse
Drahtseil / Câble	Stahlseil 1960 N/mm <sup>2</sup> / Câble en acier 1960 N/mm <sup>2</sup>
Steuerkabel / Câble de commande	Standard ≈1 Meter / Standard ≈1 mètre
Stromkabel / Câble d'alimentation	≈1 Meter mit CEE-Stecker / ≈1 mètre avec prise
Schutzart Gehäuse / Protection du boîtier	IP 55 (100-200kg IP 44)
Schutzart Steuerschalter / Protection de la commande	IP 65
Triebwerksgruppe / Classification	M5/2m (ISO/FEM)
Einschaltdauer / Starts pro Stunde / Cycle de service / Démarrages par heure	50% / 240
Isolationsklasse / Classe d'isolation	F
Einsatztemperatur / Température de fonctionnement	-10°C - +40°C
DGUV/BGV Lasttyp / Type de charge	Güter, darf nicht zum Heben von Personen verwendet werden / Marchandises, ne peuvent pas être utilisées pour soulever des personnes

## Sicherheit / Protection

Steuerschalter / Commande	Direktsteuerung mit Not-Aus / Interrupteur de commande pendentif 230/400V avec bouton d'arrêt d'urgence
Überlastschutz / Protection de surcharge	Kein Überlastschutz / Pas de protection contre les surcharges
Bremse / Frein	Mechanische Bremse, erzielt sofortige Bremswirkung und hält die Last auch bei Stromausfall sicher / Frein mécanique, permet un effet de freinage immédiat et maintient la charge en toute sécurité, même en cas de panne de courant.
Endabschalter / Fin de course	Mechanischer oberer Endabschalter / Interrupteur fin de course mécaniques supérieur



Elektrische Seilwinde DM/DT / Treuil électrique DM/DT

Optional / Optionnel



DI.0.DM.100



DI.0.DM.300

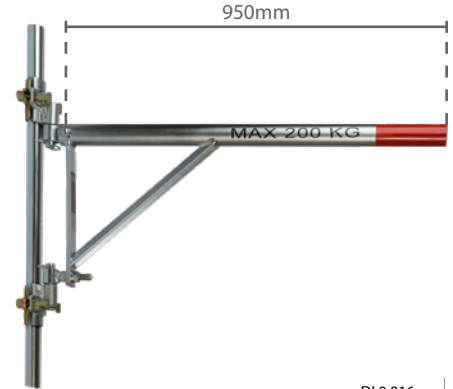

DI.0.016

Schwenkbarer Ausleger / Bras pendulaire avec accouplement  
 Zum einfachen Aufhängen an Gerüsten. (max. 200kg)  
 Pour un accrochage facile à l'échafaudage. (max. 200kg)



DI.0.DM.500



B

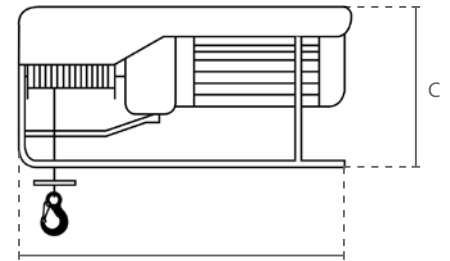

A

C

Technische Daten / Spécifications

Artikelnummer Code de l'article	Tragfähigkeit Capacité ton	Betriebsspannung Tension de fonctionnement 400V	Hubhöhe Hauteur de levage m	Max. Hubgeschwindigkeit Max. vitesse de levée m/min	Stahlkabel Câble en acier m x Ømm	Leistung Puissance kW	Eigengewicht Poids kg
DI.0.DT.300	0.3	400V	23	23	25 x 6	1.85	47
DI.0.DT.300.38			38	23	40 x 6	1.85	50
DI.0.DT.500	0.5		23	22	25 x 7	2.2	64
DI.0.DT.500.38			38	22	40 x 7	2.2	68
DI.0.DT.950	0.95		23	12	25x2 x 7	2.2	75
DI.0.DT.950.38			38	12	40x2 x 7	2.2	84

Abmessungen / Dimensions

Artikelnummer Code de l'article	A	B	C	J	K
DI.0.DM.100	375	170	240	26	22
DI.0.DM.150	415	210	310	26	22
DI.0.DM.200 / 48	510	300	385	26	22
DI.0.DM.200.98	720	300	385	26	22
DI.0.DM.300	580	305	410	26	22
DI.0.DM.500	600	300	470	26	22
DI.0.DT.300	580	305	410	26	22
DI.0.DT.500	600	300	470	26	22
DI.0.DT.950	600	300	470	36	25

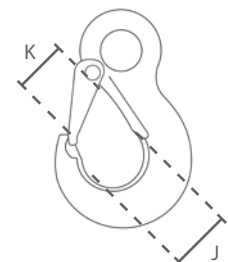



Cabrestante Eléctrico DM/DT / Electric Winch DM/DT

**Características**

- » Apto para aplicaciones de elevación y de tracción.
- » Adecuado para una gran variedad de aplicaciones industriales.
- » Ciclo de trabajo alto.
- » La transmisión permanentemente lubricada, asegura un funcionamiento suave y silencioso.
- » Se suministra listo para usar con interruptor de control, cable de alimentación, cable de acero con gancho de carga.
- » Cumple con la Directiva de Máquinas 2006/42/CE. Se suministra con certificado de pruebas, declaración de conformidad CE e instrucciones de funcionamiento.

**Features**

- » Suitable for lifting and pulling applications.
- » Suitable for a wide range of industrial applications.
- » High duty cycle.
- » Permanently lubricated transmission, ensures smooth and quiet operation.
- » Supplied ready to use with control switch, power cable and steel cable with load hook.
- » Complies with the Machinery Directive 2006/42/EC. Supplied with test certificate, CE declaration of conformity and operating instructions.



DI.0.DM.200

Especificaciones / Specifications								
Código de artículo	Capacidad	Voltaje	Altura de elevación	Máx. velocidad de elevación	Cable de acero	Consumo de energía	Peso neto	
Article code	Capacity	Operating voltage	Hoisting height	Max. lifting speed	Steel cable	Power output	Weight	
	ton		m	m/min	m x Ømm	kW	kg	
DI.0.DM.100	0.1	230V	14	15	16 x 4	0.3	15	
DI.0.DM.150	0.15		16	21	18 x 4	0.65	22	
DI.0.DM.200			23	25	25 x 5	0.75	37	
DI.0.DM.200.48	0.2		48	38	50 x 5	1.45	43	
DI.0.DM.200.98			98	38	100 x 5	1.45	50	
DI.0.DM.300	0.3		23	23	25 x 6	1.45	47	
DI.0.DM.300.38			38	23	40 x 6	1.45	50	
DI.0.DM.500			0.5	23	16	25 x 7	2.2	64
DI.0.DM.500.38				38	16	40 x 7	2.2	68

Especificaciones / Specifications	
Aplicación / Application	Cabrestante de elevación / Hoisting winch
Voltaje / Operating voltage	230V / 50Hz / 1Ph / 400V / 50Hz / 3Ph
Velocidad de elevación / Lifting speed	Velocidad única / Single speed
Cable / Cable	Cable de acero 1960 N/mm <sup>2</sup> / Steel cable 1960 N/mm <sup>2</sup>
Cable de control / Control cable	Estándar ≈1 metro / Standard ≈1 meter
Cable de energía / Power cable	≈1 metro con enchufe / ≈1 meter with plug
Protección de la carcasa / Housing protection	IP 55 (100-200kg IP 44)
Protección de control / Control protection	IP 65
Clasificación / Classification	M5/2m (ISO/FEM)
Ciclo de trabajo / Arranques por hora / Duty cycle / Starts per hour	50% / 240
Clase de aislamiento / Insulation class	F
Temperatura de funcionamiento / Operating temperature	-10°C - +40°C
Tipo de carga / Load type	Mercancías, no se pueden utilizar para levantar personas / Goods, may not be used to lift people

Protección / Protection	
Interruptor de control / Control switch	230V/400V interruptor con botón de parada de emergencia / 230/400V pendant control switch with emergency stop button
Protección de sobrecarga / Overload protection	Sin protección de sobrecarga / No overload protection
Freno / Brake	Freno mecánico, logra un frenado inmediato y mantiene la carga en caso de corte de energía / Mechanical brake, achieves immediate braking and holds the load in the event of power failure
Interruptor de límite / Limit switch	Interruptor de límite superior mecánico / Mechanical upper limit switch



Cabrestante Eléctrico DM/DT / Electric Winch DM/DT

Opcional / Optional



DI.0.DM.100



DI.0.DM.300

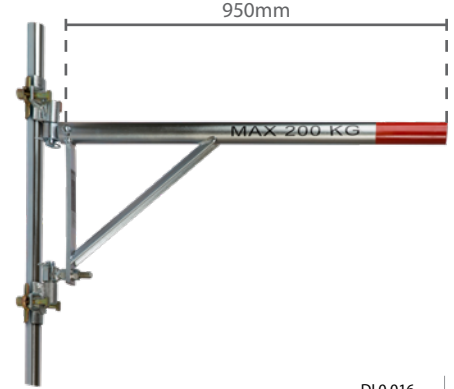

DI.0.016

Brazo pendular con enganch / Jib with hinges  
Para una fácil fijación a andamios. (max 200kg).  
For easy suspension from scaffolds. (max. 200kg)



DI.0.DM.500



B

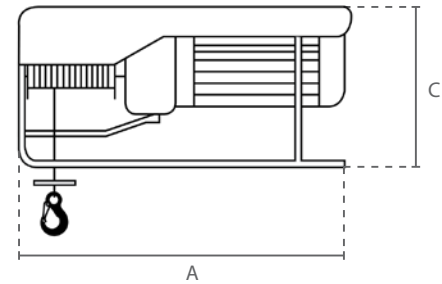

A

Especificaciones / Specifications

Código de artículo Article code	Capacidad Capacity ton	Voltaje Operating voltage	Altura de elevación Hoisting height m	Máx. velocidad de elevación Max. lifting speed m/min	Cable de acero Steel cable m x Ømm	Consumo de energía Power output kW	Peso neto Weight kg
DI.0.DT.300	0.3	400V	23	23	25 x 6	1.85	47
DI.0.DT.300.38			38	23	40 x 6	1.85	50
DI.0.DT.500			23	22	25 x 7	2.2	64
DI.0.DT.500.38	38		22	40 x 7	2.2	68	
DI.0.DT.950	0.95		23	12	25x2 x 7	2.2	75
DI.0.DT.950.38			38	12	40x2 x 7	2.2	84

Dimensiones / Dimensions

Código de artículo Article code	A	B	C	J	K
DI.0.DM.100	375	170	240	26	22
DI.0.DM.150	415	210	310	26	22
DI.0.DM.200 / 48	510	300	385	26	22
DI.0.DM.200.98	720	300	385	26	22
DI.0.DM.300	580	305	410	26	22
DI.0.DM.500	600	300	470	26	22
DI.0.DT.300	580	305	410	26	22
DI.0.DT.500	600	300	470	26	22
DI.0.DT.950	600	300	470	36	25

